

Dimensions

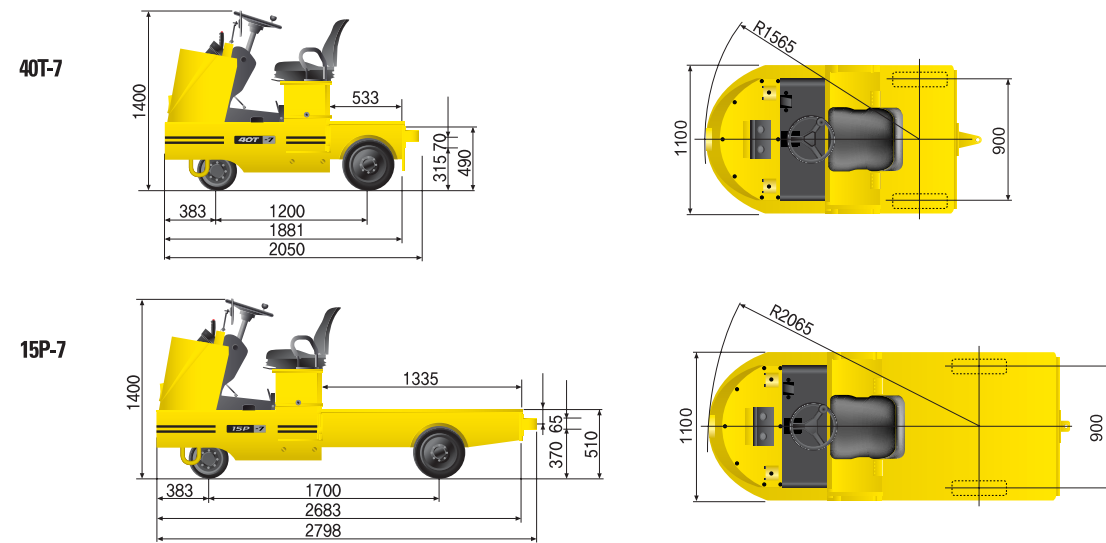

Specifications

| Description | | Unit | 40T-7 | 15P-7 |
|--------------|------------------------|----------|----------------|----------------|
| PERFORMANCE | Capacity | kg | 4,000 | 1,500 |
| | Travel Speed | Loaded | km/h | 8 |
| | | Unloaded | km/h | 10 |
| | Outside Turning Radius | mm | 1,565 | 2,065 |
| DIMENSION | Overall Length | mm | 2,050 | 2,798 |
| | Overall Width | mm | 1,100 | 1,100 |
| | Overall Height | mm | 1,400 | 1,400 |
| | Wheel Base | mm | 1,200 | 1,700 |
| | Wheel Tread - Rear | mm | 900 | 900 |
| | Weight(Unloaded) | kg | 1,250 | 1,200 |
| POWER TRAIN | Drive Motor | kw | 2.7 | 2.7 |
| | Battery | Voltage | V | 48 |
| | | capacity | AH/5HR | 280 |
| Control Type | | - | S.E.M | S.E.M |
| TIRE | Size, Front | - | φ 305 × 127(1) | φ 305 × 127(1) |
| | Size, Rear | - | 4.00-8(2) | 5.00-8-8PR(2) |

※ Materials and specifications are subject to change without notice. Metric is precise but U.S. standard may be rounded.

• Beacon lamp, Front Urethane tire, Non-Marking Tire and Cargodeck, Suspension SEAT Head guard are Optional

Electric Towing / Platform Trucks

40T/15P-7



※ Photo may include optional equipment.

HYUNDAI
HEAVY INDUSTRIES CO., LTD.
CONSTRUCTION EQUIPMENT DIVISION

HEAD OFFICE (Sales Office) 1 CHEONHA - DONG, DONG-KU, ULSAN, KOREA
TEL : (82)52)230-7970, 7729 FAX: (82)52)230-7979, 7720
U.S. Operation Hyundai Construction Equipment U.S.A., Inc.
955 ESTES AVENUE ELK GROVE VILLAGE IL. 60007
TEL : (1)847 - 437 - 3333 FAX : (1)847 - 437 - 3574
European Operation Hyundai Heavy Industries Europe N.V.
VOSSENDAAL 11, 2440 GEEL, BELGIUM
TEL : (32)14 - 562200 FAX : (32)14 - 593405 - 06

PLEASE CONTACT

www.hyundai-ce.com

2006. 6 rev.0

HYUNDAI
HEAVY INDUSTRIES CO., LTD.



The Environmentally-Friendly Electric Towing / Platform Trucks

40T/15P-7

Revolutionizing the productivity in the material industry!

Maximize the productivity of your business with our powerful and agile electric trucks.

With our vast experience in the production of construction equipment, hyundai is able to meet the demands of our consumers. Ratchet type Parking brake requires less effort 40T-7/15P-7, produced by Hyundai are not only economical, environmentally friendly and allow for convenient maintenance, but their improved maneuverability and quiet operation make our products the most widely-used towing maintenance truck in trade and distribution companies around the world.



- **Anti-rollback function** ensures smooth restarting on a slope without any move back to the rear.
- **Anti-rolloff** : This feature is designed so that if a vehicle is in a non-drive condition on a gradient, it will result in the vehicle plug braking slowly down a ramp without running away.

- **Adoption DC-DC CONVERTER CHARACTERISTIC**
 - High frequency (Silent operation)
 - Protection for short circuit, overload, reverse polarity
 - IP67 protecting rating
 - Improvement of safety & performance during the maintenance
 - Improvement of maintenance & durability

Quiet and Environmentally-Friendly 40T-7/15P-7

Hyundai's towing / platform trucks are electrically powered to provide quiet and environmentally-friendly operation for use not only in factories, but in places of business such as food plants, where hygiene and sanitation are a must.



Storage Console

A storage console is installed for the operator's benefit.



Adjustable Steering Wheel

The steering wheel can be adjusted by a lever on the right-hand side for the most comfortable operating position.



Accelerator & Brake Pedal

Based on human engineering the accelerator, brake and inching pedals are optimally positioned for convenience while operating the equipment.



Non slip-Open step

The new wide-open step. Non slip makes getting in and out easy and safe.



Easy check of hydraulic oil others



Fully hydrostatic power steering

A hydraulic steering system always guarantees smooth and flexible steering, preventing overrun and kick-back.



Front Cover

Adoption of front cover improves equipment value.



Concentrated Instrument Panel And Switch



Parking Brake System

from the operator to set.

Hyundai Forklifts Series